



Extrusion ABS, POLYLAC[®] PA-747R

V1W

Processing Conditions

- A. Pre-dry 80 °C x 2~3 hrs
 depending on a) Humidity
 b) Ratio of reground resin
 c) Storage conditions
- B. Extrusion Temperature Profile(°C)

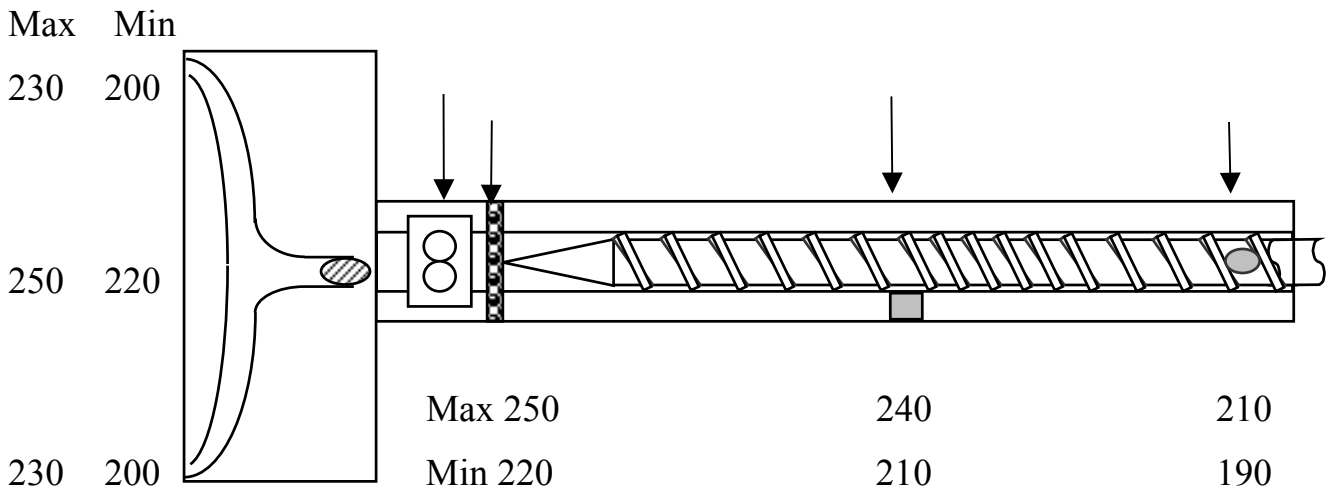

NOTE :

1. Keep the resin from dust and contamination during handling and production.
2. Do not retain the hot melt at the barrel for a long time between injection cycles.

For further information, please contact your local agent or fax to Chi Mei Technical Services Dept. at 886-6-2665555