



## Extrusion ABS, POLYLAC<sup>®</sup> PA-709S

VIW

### Processing Conditions

- A. Pre-drying 80 °C x 2~3 hrs  
 depending on a) Humidity  
 b) Ratio of reground resin  
 c) Storage conditions
- B. Extrusion Temperature Profile( °C)

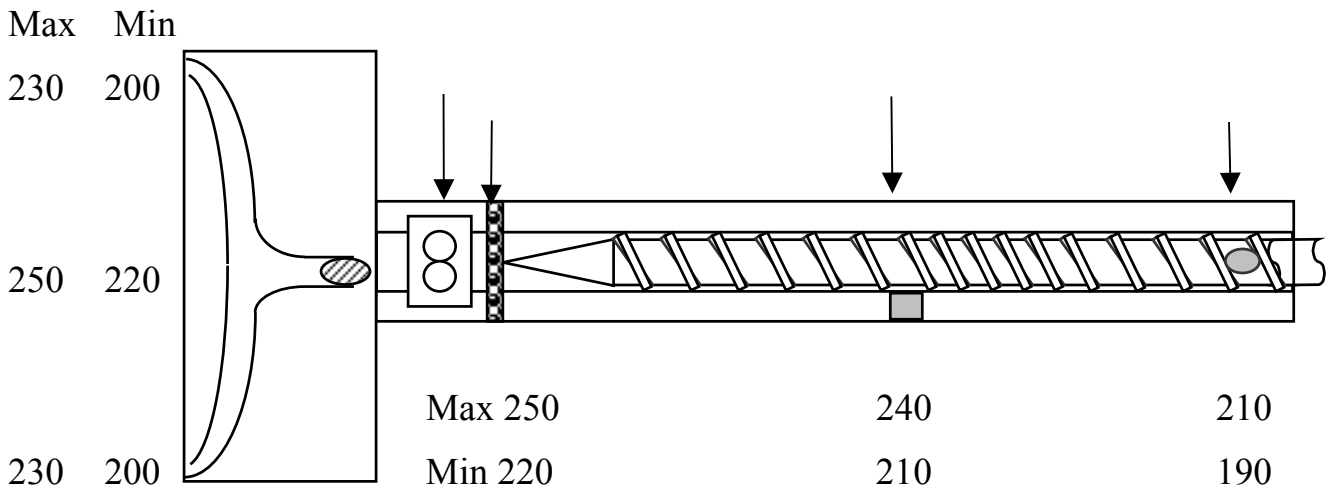

#### NOTE :

1. Keep the resin from dust and contamination during handling and production.
2. Do not retain the hot melt at the barrel for a long time between injection cycles.

For further information, please contact your local agent or fax to Chi Mei Technical Services Dept.  
 at 886-6-2665555