

# ENGINEERING POLYMERS: THE 'TOP TEN' INJECTION MOULDING PROBLEMS

R. Wilkinson, E.A. Poppe, K. Leidig and K. Schirmer



## Part 10. Deposits on mould surface.

1. Moisture in the granules
2. Feed system too small
3. Wrong gate position
4. Hold time too short
5. Wrong melt temperature
6. Wrong tool temperature
7. Poor surface finish
8. Problems with hot runners
9. Warpage
10. Mould deposit

These can occur with nearly all thermoplastics. As demands on end-products increase, so do the amounts of additives which have to be incorporated, e.g. modifiers, flame retardants, etc. These additives may quite often cause deposits to form on the mould cavity surface.

There are many other associated reasons for the formation of mould deposits. The most common ones are

- thermal decomposition
- excessive shear
- inadequate venting.

Such deposits are often due to a combination of different factors and a great deal of trouble has to be taken to find out exactly what causes these deposits to form and how to prevent them. One problem is that deposits often build up only after a few days.

### Types of deposit

Each group of additives produces a specific type of deposit. Flame retardants can react at high temperatures, forming decomposition products which may produce deposits. Impact modifiers are affected not only by excessively high temperatures but also by excessive shear. Modifiers can, under unfavourable conditions, separate from the polymer and form deposits on the cavity surface.

Pigments in engineering thermoplastics needing high melt temperatures, can reduce the thermal stability of the moulding compound, resulting in deposits consisting of polymer degradation products and decomposed pigments.

In parts of the mould which become especially hot (such as cores), modifiers, stabilisers and other additives may stick to the surface and build up deposits. In such cases, steps must be taken to achieve better mould temperature control or use special stabilisers. The table lists the possible causes of mould deposits and ways and means of preventing them.

Possible causes		Possible elimination
Thermal decomposition	Melt temperature too high, residence time too high	<ul style="list-style-type: none"> <li>• measure melt temperature and reduce to recommended level</li> <li>• check ejected compound for signs of decomposition, e.g. formation of bubbles, or gas in the melt</li> <li>• match cylinder temperature to residence time</li> <li>• ensure thermal insulation of hot runner, check temperature control and lower temperature</li> </ul>
	Dead spots in nozzle, near non-return valve, wear in cylinder, dead spots in hot runner	<ul style="list-style-type: none"> <li>• show up dead spots through changing colour. Long cleaning cycles mean poor purging</li> <li>• examine suspicious components (nozzle, adapter, screw, hot runner) for dead spots and repair or exchange</li> </ul>
	Polymers or additives with insufficient thermal stability	<ul style="list-style-type: none"> <li>• reduce residence time by using smaller cylinder. Operate with delayed feed. Ensure small melt cushion. Keep melt decompression to a minimum to prevent oxidation through sucked-in air.</li> <li>• use standard product (without modifiers, pigments etc.) experimentally.</li> <li>• pre-dry to reduce volatile constituents</li> </ul>
Too high shear	Walls too thin or flow distance too long, resulting in high shear stress	<ul style="list-style-type: none"> <li>• make walls thicker or incorporate flow aids</li> <li>• increase number of gates to reduce flow distances</li> <li>• change gating system, possibly use hot runner.</li> <li>• possibly increase melt temperature</li> </ul>
	High shear due to too small a gate	<ul style="list-style-type: none"> <li>• increase gate cross-section</li> <li>• redesign gate</li> <li>• increase number of gates</li> </ul>
	High shear due to fast injection	<ul style="list-style-type: none"> <li>• reduce or profile injection fill speed</li> <li>• increase melt temperature</li> </ul>
Insufficient venting		<ul style="list-style-type: none"> <li>• provide cavities with vents or improve venting system</li> <li>• fit self-cleaning vents to ensure consistent removal of air.</li> </ul>
Mould surface temperature too high		<ul style="list-style-type: none"> <li>• measure mould temperature after the starting-up phase and reduce to recommended level</li> <li>• reduce overheating of cores by adjusting mould temperature control</li> </ul>
<b>Possible causes and remedies for mould deposits</b> <small>Source: DuPont</small>		

10.1

## Deposits which appear suddenly

If deposits appear suddenly, this may be due to changed moulding conditions, or the moulding compound when batches are changed. The following comments may be helpful.

First of all, the melt temperature should be measured and the melt visually checked for signs of decomposition, i.e. the presence of charred particles. One should also check whether the moulding compound has become contaminated by foreign substances and that no incompatible purging compound has been used. Mould venting should also be checked. The next step should be to run the machine with natural or pastel-coloured moulding compound (but not black). The machine is then switched off after about 20 minutes' moulding. Nozzle, adapter and possibly the screw are then dismantled. Inspection of the material for charred particles, and comparing its colour with that of the original moulding compound will quickly indicate the source of the problem.

This technique has in many instances uncovered surprising weaknesses, but is really applicable only to small machines (up to, say, 40 mm screw diameter). Their elimination will also result in definite quality improvements when processing other materials. A similar procedure can be adopted for hot runner systems.

## Care of moulds

If deposits cannot be prevented from forming by any of the measures described above, special care and attention will have to be given to the moulds.

It has been found that deposits on the mould surface can be removed relatively easily in the early stages. Cavities and vents should therefore be cleaned at specified intervals, e.g. at the end of each shift. Once the deposit has formed a thick layer it is extremely difficult and time-consuming to remove it.

Because deposits vary so widely in their chemical composition, trials have to be carried out to find the most suitable solvent which will shift them. Besides the classic solvents, it has often been found that unconventional products can solve the problem, e.g. oven sprays or lemonades containing caffeine. Another trick is to use cleansing rubbers as used in model railways.

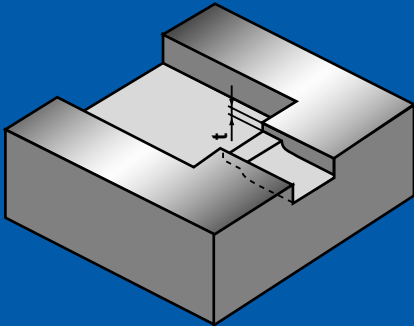

in mould parting surface

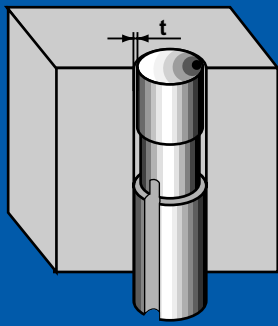

using ejector

Material	t*
POM	0,03 mm
PA	0,02 mm
PET	0,02 mm
PBT	0,02 mm
TEEE	0,03 mm

\* in the case of low viscosity grades and where there must be a minimum amount of flash, vent slits should be shallower to start with

Recommendation for vent depth

**Typical vent designs**

Source: DuPont

10.2

## Recommendations on preventing deposits

If thermally sensitive compounds are moulded using hot runners, it should be remembered that the residence time will be longer, so that the risk of deposits consisting of degradation products will be greater.

Shear sensitive materials should always be processed using generously dimensioned runners and gates. Multi-point gating, which reduces flow distances and thus enables moulders to reduce injection speeds, have given good results.

Generally speaking, efficient mould venting reduces the tendency to form deposits. Adequate venting should therefore be provided at the mould design stage. Self-cleaning vents, or those from which deposits can be easily removed, are to be preferred. Improvements in the venting system have often led to reduced deposits on the tool.

In some instances it is possible to apply a special non-stick coating to the cavity surface, which will prevent deposits building up. Tests should be carried out to assess the effectiveness of such coatings. Titanium nitriding has often reduced the rate at which deposits build up on the tool.



10.3

**EUROPE/MIDDLE EAST/AFRICA**

Belgique / België  
Du Pont de Nemours (Belgium)  
Antoon Spinoystraat 6  
B-2800 Mechelen  
Tel. +32 15 44 14 11  
Telefax +32 15 44 14 09

Bulgaria  
Serviced by  
Biesterfeld Interrowa GmbH & Co. KG.  
See under Österreich.

Ceská Republika a  
Slovenská Republika  
Du Pont CZ, s.r.o.  
Pekarska 14/268  
CZ-155 00 Praha 5 – Jinonice  
Tel. +42 257 41 41 11  
Telefax +42 257 41 41 50-51

Danmark  
Du Pont Danmark ApS  
Skjøtevej 26  
P.O. Box 3000  
DK-2770 Kastrup  
Telefax +45 32 47 98 05  
Telefax +45 32 47 98 05

Deutschland  
Du Pont de Nemours  
(Deutschland) GmbH  
Du Pont Straße 1  
D-61343 Bad Homburg  
Tel. +49 6172 87 0  
Telefax +49 6172 87 27 01

Egypt  
Du Pont Products S.A.  
Bldg no. 6, Land #7, Block 1  
New Maadi  
ET-Cairo  
Tel. +202 754 65 80  
Telefax +202 516 87 81

España  
Du Pont Ibérica S.A.  
Edificio L'Ilia  
Avda. Diagonal 561  
E-08029 Barcelona  
Tel. +34 227 60 00  
Telefax +34 227 62 00

France  
DuPont de Nemours (France) SAS  
Défense Plaza  
23/25 rue Delarivière Le Foullon  
Défense 9  
92 064 La Défense Cedex  
Phone: +33 (0)1 41 97 44 00  
Telefax +33 1 47 53 09 67

Hellas  
Biesterfeld Hellas Intralink S.A.  
Trading Establishment  
149, AG, Triados Menidi Acharnes  
GR-13671 Athens  
Tel. +30 210 24 02 900  
Telefax +30 210 24 02 141

Israël  
Gadot Chemical Terminals (1985) Ltd.  
16 Habonim Street  
Netanya – South Ind. Zone  
IL-42504 Netanya  
Tel. +972 3 526 42 41  
Telefax +972 3 528 27 17

Italia  
Du Pont de Nemours Italiana S.r.L.  
Centro Direzionale "Villa Fiorita"  
Via Piero Gobetti, 2/A  
20063 Cernusco s/N (MI)  
Tel. +39 02 92629.1 (switchboard)  
Fax +39 02 36049379

Magyarország  
DuPont Magyarország Kft.  
HU - 2040 Budaörs  
Neuman J.u. 1  
Tel. +36 23 509 400  
Telefax: +36 23 509 432

Maroc  
Deborel Maroc S.A.  
40, boulevard d'Anfa – 10°  
MA-Casablanca  
Tel. +212 227 48 75  
Telefax +212 226 54 34

Norway / Norge  
Distrupol Nordic  
Ostenssloveien 36  
N-0677 Oslo  
Tel. +47 23 16 80 62  
Telefax +47 23 16 80 62

Österreich  
Biesterfeld Interrowa GmbH & Co. KG  
Bräuhausgasse 3-5  
P.O. Box 19  
AT-1051 Wien  
Tel. +43 1 512 35 71-0  
Fax +43 1 512 35 71-31  
e-mail: info@interrowa.at  
internet: www.interrowa.at

Polska  
Du Pont Poland Sp. z o.o.  
ul. Powazkowska 44C  
PL-01-797 Warsaw  
Tel. +48 22 320 0900  
Telefax +48 22 320 0910

Portugal  
Biesterfeld Iberica S.L.  
Rua das Matas  
P-4445-135 Alfena  
Tel. +351 229 698 760  
Telefax +351 229 698 769

Romania  
Serviced by  
Biesterfeld Interrowa GmbH & Co. KG.  
See under Österreich.

Russia  
DuPont Russia LLC.  
ul. Krylatskaya 17/3  
121614 Moscow  
Tel. +7 495 797 22 00  
Fax. +7 495 797 22 01

Schweiz / Suisse / Svizzera  
Biesterfeld Plastic Suisse GmbH  
Dufourstrasse 21  
Postfach 14695  
CH-4010 Basel  
Tel. +41 61 201 31 50  
Telefax +41 61 201 31 69

Slovenija  
Serviced by  
Biesterfeld Interrowa GmbH & Co. KG.  
See under Österreich.

Suomi / Finland  
Du Pont Suomi Oy  
P.O. Box 54 (Keilaranta 12)  
FI-02150 ESPOO  
Tel. +358 207 890500  
Fax: +358 207 890501

Sverige  
Serviced by  
Du Pont Danmark ApS.  
See under Danmark.

Türkiye  
Du Pont Products S.A.  
Buyukdere Caddesi No. 122  
Ozsezen Ismerkezi, A block, Kat: 3  
Esentepe, 34394 Istanbul  
Tel. +90 212 340 0400  
Telefax +90 212 340 0430

Ukraine  
Du Pont de Nemours  
International S.A.  
Representative Office  
3, Glazunova Street  
Kyiv 252042  
Tel. +380 44 294 96 33 / 269 13 02  
Telefax +380 44 269 11 81

United Kingdom  
Du Pont (UK) Limited  
Wedgwood Way  
Stevenage  
Hertfordshire SG1 4QN  
Tel. +44 1438 734000  
Telefax +44 1438 734109

South Africa  
DuPont de Nemours  
Societe Anonyme  
South African Branch Office  
4th Floor Outspan House  
1006 Lenchen Avenue North  
Centurion  
Pretoria 0046  
Tel. +27 0 12 683 5600  
Telefax +27 0 12 683 5661

**NORTH AMERICA**

USA  
DuPont Engineering Polymers  
Barley Mill Plaza, Building 26  
P. O. Box 800026  
Wilmington, Delaware 19880  
Tel. +1 302 992 4592  
Telefax +1 302 992-6713

DuPont Automotive  
950 Stephenson Highway  
P.O. Box 7013  
Troy, MI 48007-7013  
Tel. +1 248 583-8000

Canada  
DuPont Engineering Polymers  
P.O. Box 2200  
Streetsville, Mississauga  
Ontario, Canada L5M 2H3  
Tel. +1 905 821-5953

Mexico  
DuPont S.A. de C.V.  
Homero 206  
Col. Chapultepec Morales  
11570 Mexico D.F.  
Tel. +525 557 221 000

**SOUTH AMERICA**

Argentina  
Du Pont Argentina S.A.  
Avda. Mitre y Calle 5  
(1884) Berazategui-Bs.As.  
Tel. +54 11 4239-3868  
Telefax +54 11 4239-3817

Brasil  
DuPont do Brasil S.A.  
Al. Itapecuru, 506 Alphaville  
06454-080 Barueri-Sao Paulo  
Tel. +5511 7266 8229

**ASIA-PACIFIC**

Australia  
DuPont (Australia) Ltd.  
168 Walker Street  
North Sydney NSW 2060  
Tel: +612 9923-6111  
Fax: +612 9923 6011

Hong Kong/China  
DuPont China Ltd.  
26/F, Tower 6, The Gateway,  
9 Canton Road  
Tsimshatsui, Kowloon, Hong Kong  
Tel: +852 2734 5345  
Fax: +852 2724 4458

Shanghai/China  
DuPont China Holding Co. Ltd.  
15/F, Shui On Plaza  
333 Huai Hai Road (Central)  
Shanghai 200021  
Tel: +86 21 6386 6366  
Fax: +86 21 6386 6333

India  
E.I. DuPont India Limited,  
"Arihant Nitco Park" Sixth floor,  
90, Dr. Radhakrishnan Salai,  
Mylapore,  
Chennai 600 004  
Tel: +91 44 28472800  
Fax: +91 44 28473800

Japan  
DuPont Kabushiki Kaisha  
Sanno Park Tower, 11-1  
Nagata-cho 2-chome  
Chiyoda-ku, Tokyo 100-6111  
Japan.  
Tel: +81 3 5521 8500  
Fax: +81 3 5521 2595

Korea  
DuPont (Korea) Ltd.  
4/5 Floor, Asia Tower  
#7/26, Yeoksam-dong, Kangnam-Ku  
Seoul 135-082  
Tel: +822 2222-5200  
Fax: +822 2222-5470

Singapore  
Du Pont Company (S) Pte Ltd  
1 HarbourFront Place #11-01  
HarbourFront Tower One  
Singapore 098633  
Tel: +65 6586 3688  
Fax: +65 6272 7494

Taiwan  
DuPont Taiwan Ltd.  
Hung Kuo Building, 13th floor  
#167 Tun Hwa North Road  
Taipei 105  
Tel: +8862 2719-1999  
Fax: +8862 2719-0852

Thailand  
DuPont (Thailand) Limited  
6-7th Floor, M. Thai Tower  
All Seasons Place  
87 Wireless Road  
Lumpini, Phatumwan  
Bangkok 10330  
Tel: +66 2 659 4000  
Fax: +66 2 659 4001

**CRASTIN® PBT**  
THERMOPLASTIC  
POLYESTER RESIN

**DELTRIN®**  
ACETAL RESIN

**HYTREL®**  
THERMOPLASTIC  
POLYESTER ELASTOMER

**MINLON®**  
MINERAL REINFORCED  
NYLON RESIN

**RYNITE® PET**  
THERMOPLASTIC  
POLYESTER RESIN

**THERMX® PCT**  
HIGH PERFORMANCE POLYESTER

**TYNEX®**  
NYLON MONOFILAMENT

**VESPEL®**  
PARTS AND SHAPES

**ZYTEL®**  
NYLON RESIN

**ZYTEL® HTN**  
HIGH PERFORMANCE  
POLYAMIDE

**ZENITE® LCP**  
LIQUID CRYSTAL POLYMER

**DUPONT® ETPV**  
THERMOPLASTIC RUBBER  
THAT RESISTS OIL & HEAT

*The DuPont Oval Logo, DuPont™, The miracles of science™, and Crastin®, Deltrin®, DuPont® ETPV, Hytrel®, Minlon®, Rynite®, Thermx®, Tynex®, Vespel®, Zytel®, Zenite® are registered trademarks or trademarks of DuPont or its affiliates.*

The information set forth herein is furnished free of charge and is based on technical data that DuPont believes to be reliable. It is intended for use by persons having technical skill at their own discretion and risk. DuPont makes no warranties, express or implied, and assumes no liability in connection with any use of this information.

©2007 E.I. du Pont de Nemours and Company



The miracles of science™