



Extrusion ASA, KIBILAC[®] PW-997S

June 29, 2006 VIW

Processing Conditions

- A. Pre-dry 80°C x 2~3 hrs
depending on
- a) Humidity
 - b) Ratio of reground resin
 - c) Storage conditions
- B. Extrusion Temperature Profile(°C)

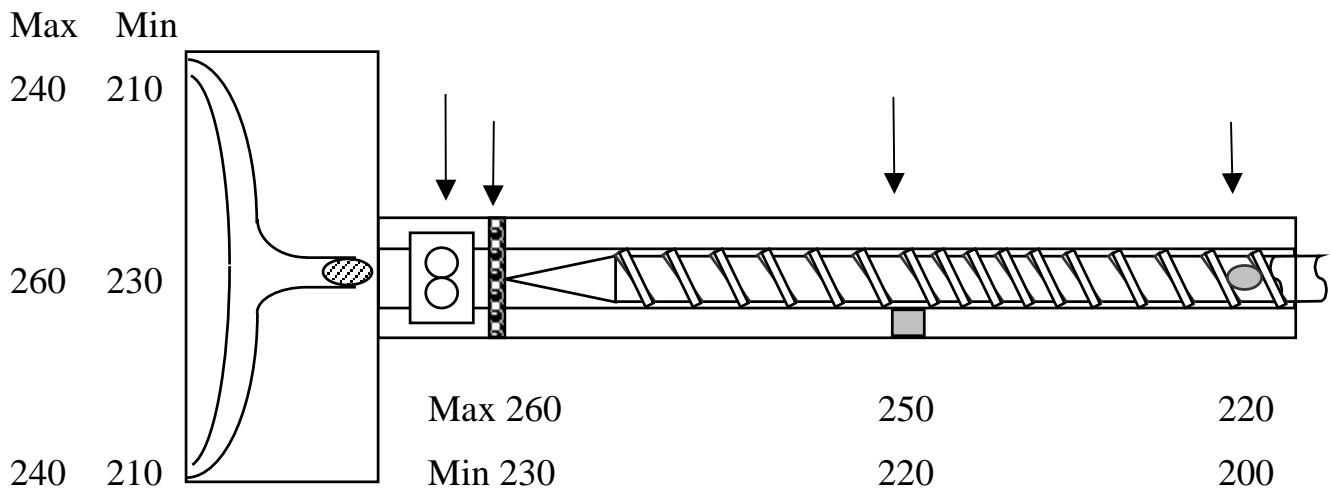

NOTE :

1. Keep the resin from dust and contamination during handling and production.
2. Do not retain the hot melt at the barrel for a long time between injection cycles.

For further information, please contact your local agent or fax to Chi Mei Technical Services Dept. at 886-6-2665555